

## Introduction heat exchange

*The aim of Emplove is to contain and if possible reduce the overall levels of energy use per unit of production. Heat exchange provides an avenue to get more out of your energy.*

### The Challenge

The Emplove process can be a major contributor to a company's improved productivity and profitability, and should be treated in precisely the same way as any other investment in plant and equipment. Thus the servicing of capital investments, maintenance and labour costs are all factors which must be considered in addition to energy costs before a proper judgement can be made.

Energy management includes consideration of whether:

- the process is required at all e.g. separating of waste distillation products for disposal, and then recombining for destruction by incineration;
- a different substitute process is available e.g. the use of hot water in place of steam;
- good housekeeping and maintenance are practised e.g. defective insulation is replaced;

- appropriate control to avoid waste is being practised.

If heat recovery is being considered, two further preliminary questions must be answered:

- can heat generation be reduced by switching to another fuel? e.g. a change from indirect heating using oil fuels to direct heating with natural gas; or a change from a dirty fuel to a clean fuel with an increase in heat transfer rate because of the absence or reduction of fouling.
- is heat recovery practical? It may not be, because of distance between process streams, or because of a low differential in temperatures.

Heat recovery involves the use of waste heat from one process for a useful purpose (in the same or different process) to reduce the total energy required by the plant.

Before heat recovery is considered, it is important to first ascertain that the production of waste heat cannot economically be avoided. It would be pointless to install a heat recovery system when the waste heat could be greatly reduced through adjustment and maintenance of the equipment, better control of the process or replacement by a more efficient process.

The best application for recovered heat is in the process where it is generated, as proximity in both space and time is generally assured.

Recovered heat in the form of hot gases generally cannot be transmitted economically over distances exceeding 30 metres; but in the form of hot liquids this distance may be upwards of 300 metres.

## Fundamentals

Before getting involved in specific heat exchangers and their applications, it is useful to have a basic understanding of the ways heat energy transfers from one process stream to another.

Heat will flow of itself from a hotter body to a cooler body, and it does so by one or more of three mechanisms:

- Conduction
- Convection
- Radiation

**Conduction** occurs when one side of a (metal) plate is heated, and the heat is transferred to the other side. Note that the plate need not be metal - the phenomenon is universal. Conduction follows a very simple law:

$$Q = C A (T_h - T_c)$$

Q = rate of heat flow (Watts)

C = conductance of wall (W/m<sup>2</sup>.K)

A = cross-sectional area (m<sup>2</sup>)

T<sub>h</sub> = temperature of hot face (K)

T<sub>c</sub> = temperature of cold face (K)

**Conductance** is the reciprocal of a thermal resistance; so flow of heat follows exactly the same sort of law as flow of electricity:

$$\text{Ohm's Law: } I = V/R$$

I = current (amps)

V = voltage distance (volts)

R = resistance (ohms)

It will be obvious that less heat will flow through a thick plate than through a thinner one, and more will flow through a copper plate than through a steel plate of the same thickness. The heat conduction properties of materials are expressed as "Conductivity" k (Watts/metre Kelvin) - which is simply the conductance for a plate of unit thickness.

Heat transfer by conduction is usually not very important in industrial practice, because the resistance to heat flow offered by a solid wall is normally much less than the resistance to heat flow in and out of the surface. The mechanism that governs this flow is convection.

**Convection** is the process of transferring heat between a flowing fluid - gas or liquid - and a solid surface. The heat

itself, may move the fluid (i.e. hot air becomes lighter as it is heated and so rises). Convection under this condition is called "natural convection".

If the fluid is moved by an external force (i.e. fan or pump) this is called "forced convection" and is the normal situation in an industrial heat exchanger.

When a fluid moves with respect to a solid surface, there is always a stationary film of fluid in contact with the surface. The heat has to travel through this film to move to or from the surface. The thermal resistance of this surface film or boundary layer greatly impedes the flow of heat, to the extent that design of forced convection heat exchangers is mainly concerned with estimating the film resistance.

For an exchanger which transfers heat from one fluid to another through a metal wall. This demonstrates the fallacy of the common view that "you will get more heat through a copper wall than through a stainless steel one because copper has a higher thermal conductivity". In fact, the resistance of the fluid film is usually so much higher than that of the metal that the latter can be neglected altogether in calculating heat transfer.

"A" and "B" shows the temperature drops that occur when heat from a furnace flows through the walls of a metal tube to a liquid flowing inside. The temperature of the metal depends on the rate of heat flow and the resistance offered to heat flow by the metal and the thin boundary liquid film at the inside tube surface.

"A" shows the relative level of temperatures when the resistance offered by the liquid film is low. "B" shows the relative increase in metal temperature for the same rate of heat flow when the resistance offered by the liquid film is high. Resistance to heat flow by the liquid film is a function of fluid velocity, viscosity, specific heat, thermal conductivity, specific gravity and tube diameter.

Unfortunately there is no simple way to measure the thickness of the fluid film on a heat transfer surface. "Film heat transfer coefficients" which represent the

effect of fluid films have been derived from experiment, and are available in published tables for many fluids and various arrangements of heating surface. It is important to understand that most published heat transfer coefficients are approximations at best and that a slightly dirty surface or an impure fluid can give a very significant reduction in the effective coefficient.

Figure 1: Resistance to heat flow

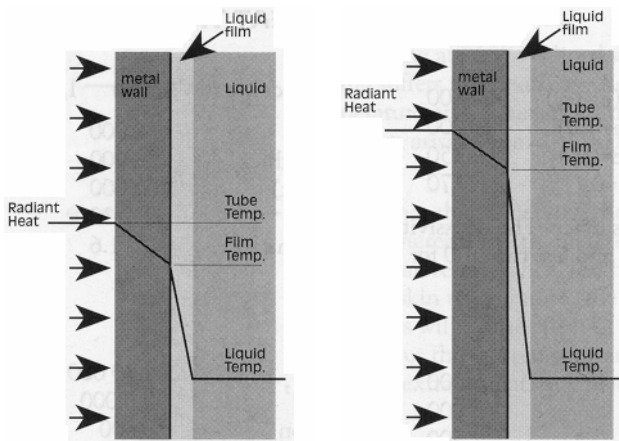

A low film resistance

B high film resistance

As before,

$$Q = h A (T_f - T_s)$$

$h$  = film heat transfer coefficient ( $W/m^2.K$ )

$T_f$  = temperature of fluid (K)

$T_s$  = temperature of surface (K)

The temperature difference will be reversed for heat flow to the bulk fluid from the wall.

A special case of heat transfer, differing from the general case of convection occurs when a pure liquid boils, or is condensed, on a surface. The generation of steam for heating is the most common example. Provided that the surface is clean, very high rates of heat transfer can be obtained - usually far higher than would be possible with forced convection.

For condensing, it is essential that the vapour or liquid be reasonably pure. If steam is condensed on a cool surface and the steam contains some air, an air film will build up on the surface and greatly impede heat transfer.

Similarly, evaporating impure water will lead to dirty or scaled heat transfer surfaces which will transfer heat much

more slowly than will a clean surface, both under boiling and forced convection conditions.

**Radiation** is the transferring of heat by electromagnetic means - like light. If the temperature is high enough, this radiation can be seen as from a red-hot piece of steel. But heat radiation can also be felt at quite low temperatures - as from a stone wall that has been warmed by the sun. Heat transfer by radiation is governed by laws which are entirely different from those that control conduction and convection. With conduction and convection the rate of heat flow from the hotter to the cooler body is proportional to the temperature difference between them. With radiant heat transfer, the rate of heat flow between the two bodies is proportional to the difference between the fourth powers of their absolute temperatures.

At low temperatures, radiant heat transfer is usually much less important than convection, but at high temperatures the reverse is the case. A thorough understanding of radiant heat transmission is also required in heating and ventilating work, and lack of that understanding is one of the most common causes of unsatisfactory indoor comfort heating and cooling.

Heat radiation, like light, travels in straight lines and some media, such as air, are substantially transparent to it, whilst other media, such as water and carbon dioxide, are transparent to light but not to heat radiation. Every body that is at a temperature above absolute zero (0 Kelvin or  $-273^{\circ}$  Celsius) emits heat radiation and because the emission is proportional to the fourth power of the absolute temperature, it increases very rapidly with temperature. This is obvious if one holds one's hand too close to the element of a radiant-type electric heater. Heat exchangers that depend chiefly on radiation are widely used in high temperature industries.

## SOME TYPICAL HEAT TRANSFER COEFFICIENTS

<b>Conduction</b> ie. Resistance	(W/m <sup>2</sup> -K)	1/h <sub>tc</sub> (m <sup>2</sup> -K/W)
Copper (1.5mm thick)	250,000	0.000004
Stainless Steel (1.5mm thick)	12,000	0.00008
Boiler Scale (1mm thick)	2,000	0.0004
Firebrick (25mm thick)	30	0.033
Mineral Wool (25mm thick)	1.6	0.625
<b>Convection</b>		
Condensing Steam	5,000 - 30,000	0.0002 - 0.00003
Water heated in tubes	500 – 6,000	0.002 - 0.00017
Air-Forced Convection	30 - 300	0.033 - 0.0033
Air-Natural Convection	5 - 30	0.2 - 0.033
<b>Radiation</b>		
From 1,500°C to 100°C (e = 1.0)	560,000	0.000005
From 800°C to 100°C (e = 1.0)	75,000	0.000013
From 250°C to 100°C (e = 0.1)	350	0.0033
From 100°C to 20°C (e = 0.1)	70	0.015

Where e = emissivity of surface. The emissivity is 1.0 for a perfect absorber/emitter and less than 1.0 for real surfaces.

### Fouling Factors

Steam	5,000	0.0002
Water	5,000	0.0002
Air	2,500	0.0004

The overall heat transfer coefficient is the reciprocal of the sum of the resistances ie:

$$1/H = 1/h_1 + 1/h_2 + 1/h_3 + \dots$$

H = overall heat transfer coefficient (W/m<sup>2</sup>. K)

h<sub>1</sub>, 1/h<sub>2</sub>, h<sub>3</sub> ..... = individual film and wall coefficient (W/m<sup>2</sup>.K)

## A case in point

A furnace operating at 760°C is lined with a fire brick refractory, and suffers from excessive heat loss and a very high surface temperature on the outside of the steel shell. This is a common problem arising from a misjudgment of the overall heat transfer.

One solution (other than accepting the current situation as inevitable) is to increase the thermal resistance to reduce

the rate of heat loss (more resistance, less heat flow) and to reduce the outer skin temperature (the greater the total resistance, the less will be the effect: of the outside film resistance, and thus the less temperature difference across that film). Therefore, extra insulation will assist in the solution of both problems.

Figure 4: Heat loss through furnace wall

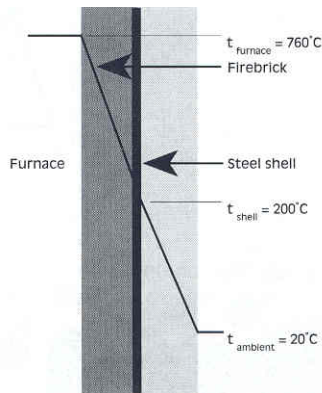

But where should the insulation be added?

### Option One

Insulation is added to the outside of the furnace.

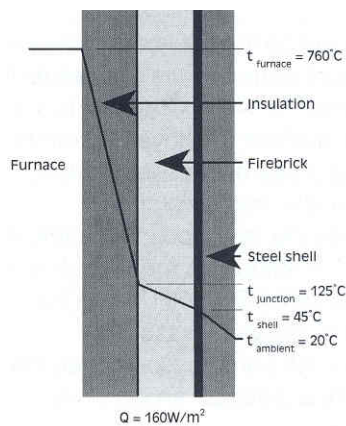

This is the simplest and cheapest apparent remedy - but what has happened to the temperature of the steel shell?  $680^{\circ}\text{C}$  will cause scaling and probable failure of the mild steel.

### Option Two

Insulation is added to the inside of the furnace.

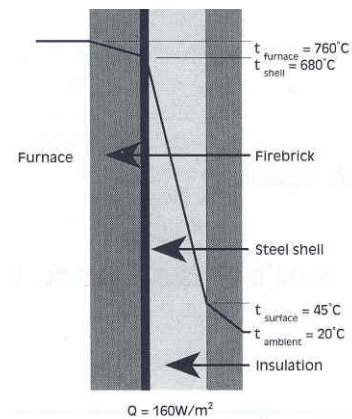

This requires a higher grade insulation, and is more difficult to install. It may also require redesign of the furnace. It is, however, the correct solution in most cases.

## Heat exchange types

Heat exchangers can be divided into two separate categories, those in which the two fluids (liquid or gas) are in direct contact, and those in which the fluids are separated (indirect).

The first category is small compared to the second, but should not be neglected. There are four common types:

1. **Cooling Tower:** used extensively in air conditioning for heat removal from water. In the cooling tower it is the water which is the process fluid, with the air being used as a heat sink, and rejected. The use of cooling towers is well understood, and the only difficulties are likely to be ensuring that cleanliness is maintained in the system to prevent legionella.
2. **Air Washer:** is similar to the cooling tower in principle, but differs in that the air is the process fluid, with the water being used as a heat sink. The air washer can be a very effective device, particularly at (but not limited to) high humidities. In some cases the water also may be used in further processes.
3. **Spray Condenser:** used in boiler systems, using the condensation of low grade steam to preheat feedwater or for the supply of wash water. It can also be used for the condensation of odorous vapours, prior to incineration of the non-condensable fractions. Caution must be exercised, however, that the malodours are not then transferred to the condensing liquid without being eradicated.

4. **Direct Fired Air Heater:** is a special application of the direct contact heat exchanger, in which energy is transferred from the fuel fluid (normally natural gas) to an air stream for space heating or for drying processes. If the fuel or its exhaust gases are incompatible with the process, an indirect fired air heater would be more appropriate.

The second category (indirect), where the fluids are separated by a dividing membrane through which heat is transmitted from one to the other is by far the most common, but has a further sub-group which falls between the two categories, and that is one in which the fluids are separated in time. These are the periodic heat exchangers, which utilise a heat storage medium to absorb heat from the one fluid, store it for a period, and then give it up to the second. There are three main types which may be of use.

5. **Heat Wheel:** used mainly in air conditioning work to transfer heat (and sometimes moisture) from exhaust air to fresh incoming air. The wheel is constructed from a high thermal mass material and is so positioned that exhaust air passes through a portion of the wheel, and the incoming air passes through another portion. Between the two may be a purge section to act as a seal. The wheel rotates slowly to absorb the exhaust heat into itself, to travel through the purge section and then release the heat to the incoming air. Cross-contamination can be a problem which may limit its use in some cases. Heat Wheels are available with ceramic cores for use at quite elevated temperatures.

6. **Regenerator:** used extensively in high temperature industries, notably in the manufacture of steel, glass, and high temperature ceramics. In this case, the heated air or gas flow (i.e. to a furnace) is directed through a "checkerwork" of brick, somewhat similar in construction to an ornamental open-weave block wall, whilst the furnace exhaust gases are directed through a separate section of "checkerwork". After a time, the gas flows are alternated and the heat absorbed from the one stream is given up to the second.

7. **Cold Storage:** usually in the form of ice. Used in chilled water air conditioning systems to minimise refrigeration plant size. At times of low cooling demand, or in times of off-peak electrical charging, the refrigeration plant produces ice with the capacity available in excess of the required building load. At peak load times, the ice is remelted to add to the available chilled water capacity. In a typical diurnal cooling demand, such a periodic heat store is used to shave the high peak loadings to fill the troughs. The advantages are twofold, to reduce the installed capacity of the refrigeration plant, and to allow it to run at peak efficiency for much of its operation.

Now back to the major category, where the two fluids are separated in space by a conducting, dividing membrane.

8. **Evaporative Cooling Tower:** differs from heat exchanger type 1 in that the process fluid is separated from the evaporating water in the tower. In construction, it is a cooling tower with pipe coils. The coils are wetted by the water which cascades through the airstream, giving up heat from the process fluid to the water, and hence to the air. The separation of the process fluid and the air allows the tower to be used for cooling of fluids which could not normally be used in a cooling tower, but at the cost of a greater temperature separation.

9. **Shell and Tube:** probably the most versatile form of heat exchanger. It has a wide range of styles, from single tube coaxial exchanger (of which the jacketed vessel is a derivative), to multitube multipass units. The tubes may be straight (which allows easy mechanical cleaning) or of a hairpin configuration. In each case, one fluid passes through the tube(s) whilst the other fluid is passed around the outside, usually within a confining shell. The shell-side fluid is frequently baffled to improve heat transfer by the generation of turbulence (to decrease the thickness of the boundary layer). Shell and tube exchangers can be used where the two fluids have similar film heat transfer coefficients, and where the shell-side fluid is essentially non-fouling. The fluids are usually (but not always) liquids.

10. Plate Heat Exchanger: although not as common as the shell and tube, it is widely used, particularly in food industries for liquid to liquid heat transfer. The plate heat exchanger, along with the following two types, is one of a family of "compact" heat exchangers, so called because of the high rates of heat transfer achieved. The heat transfer coefficients are typically twice those realised in shell and tube exchangers. The high turbulence of the fluids as they flow between the plates also minimises fouling, and such as does occur can easily be removed by disassembly of the plates. Care may be needed to ensure that the gasket and plate materials are compatible with the process fluids.
11. Lamella Heat Exchanger: is a derivative of the plate exchanger, configured to be similar to a single pass shell and tube exchanger. The heat transfer coefficients are as for the plate exchanger, but cleaning is by chemical means. The lamellas are normally fully welded, with no gaskets being needed.
12. Spiral Heat Exchanger: another variant of the plate exchanger, in which the fluid channels are formed into two spiral parallel channels. Heat transfer coefficients are similar to those in the plate exchanger. The spiral exchanger is especially suited to applications subject to thermal shock. It can be arranged to provide either parallel flow, counterflow or crossflow. As with the lamella exchanger, the channels are fully welded. These are used where plugging would be a problem, e.g. lint-laden wash water, sewage sludge.
13. Extended Surface Heat Exchanger: used when the film heat transfer coefficients of the two fluids are widely dissimilar, as in heat transfer between a liquid and a gas. The car "radiator" is an example of an extended surface convection heat exchanger. In this exchanger type, more surface area is provided on the gas-side of the exchanger to compensate for the much lower film heat transfer compared to that on the liquid side. The extended surface may be on the inside or outside of the tubes, depending on the application.
14. Run-Around Coil: is a particular application of the extended surface exchanger. It consists of a pair of such exchangers, in air or gas streams which may be separated in space. The two exchangers are liquid-coupled by a pumped loop which merely transfers heat over the separation distance from one to the other. A typical application may be in an air conditioning unit arranged for dehumidification by cooling the airstream to drop out excess moisture, followed by reheating back to something approaching the original temperature.
15. Heat Pipe: is a relatively new type of exchanger which combines the principles of a heat exchanger with those of a refrigerator. Typically it consists of a single tube, finned at each end, which is sealed with a small refrigerant charge and a wick inside. The tube is at a slight angle to allow condensing refrigerant to flow from the upper to the lower end. The wick acts as a pump to transfer the liquid refrigerant back to the upper end. The upper section of the tube acts as an evaporator, whilst the lower end acts as the condenser. Heat pipes are available which will operate at up to about 500°C, for duties such as preheating of oven supply air by the hot exhaust gases.
16. Fluid Bed: is generally a combustion process in which a solid fuel is combusted in a highly agitated "sand" bed. The bed is "fluidised" to the extent that it acts as a free flowing liquid. Tubes placed in this bed are subject to extremely high heat transfer rates as the surface film is practically non-existent. Such a device gives very effective heat transfer between the "solid" surrounding the tube, and the liquid within. There are quite large steam boilers in operation which use this principle.

The above list of examples of heat exchanger types does not represent every type of heat exchanger in use, but is more an indication of what is available.

## Some Constraints

The effective use of heat exchangers depends on the correct matching of exchanger type to the duty required, and it is important that a correct assessment and evaluation is made at a very early stage. Each type of exchanger has its place, and each has applications in which it should not be used.

The following check list is a starting point for heat exchanger selection:

**Space Availability** (Relative locations of the process streams): Are they adjacent or widely separated, and can they economically be repositioned?

**Temperatures:** Both in terms of absolute temperatures, and in terms of temperature difference between the process streams.

**Compositions:** Are they solids, liquids, gases or vapours? Are they both the same, or are they different?

**Contamination:** Is some leakage between the process streams acceptable, or must they be totally isolated at all times? Is hygiene critical?

**Fouling:** Are either or both of the process streams likely to foul the exchanger surfaces? Should allowance for dirt build-up be made when sizing the heat transfer surfaces? Will the presence of deposits cause failure of the unit?

**Cleanability:** How critical is it to gain access to all parts of the exchanger surfaces for mechanical cleaning? Is chemical cleaning appropriate?

**Corrosion:** Are either of the process streams likely to corrode the heat transfer surface and are special materials required? Note that the cause of corrosion may not be immediately obvious - as in acid condensation from flue gases once the temperature drops to the apparatus dew point.

**Pressure Drop:** What pressure drop is acceptable before the process(es) associated with the process streams are unacceptably affected?

**Material Selection:**

**Safety:** What are the consequences of leakage? Are there risks to the operators if and when the exchanger has to be cleaned? Are there any other safety considerations which must be taken into account?

**Cost:** Is there a cost benefit in the installation of the heat exchanger? What constraints are there in terms of total capital expenditure? Or payback time?

**Regulatory Requirements:** Is the installation design governed by regulations such as the Dangerous Goods Regulations or the Boiler Code? Is the installation needed to comply with Trades Waste bylaws (in terms of temperature or composition of a waste stream) or the Resource Management Act (in terms of discharges)?

## Examples

### A) Pasteurisation

This is the classic example of a heat exchanger used to achieve almost complete energy recovery. By the use of a Plate Heat Exchanger, over 96% of the energy required to raise the incoming milk temperature from its storage temperature of 5°C to the pasteurisation temperature of 72°C is recovered from the pasteurised milk as its temperature is again dropped to 5°C for further processing and storage.

### B) Packing Room Air Conditioning

In the air conditioning of a Dairy Products Powder Packing Room, the fresh air make-up has to

compensate for a very high powder-contaminated air extraction rate. As the ventilation system is typically based on total-loss once-through air movement, and the room needs to have its temperature and humidity controlled within narrow bands, energy costs can be significant. One method of reducing these costs has been to pass the exhaust air through high-efficiency cyclones and/or bag filters (to remove the airborne powder) and then through a Total Enthalpy Heat Wheel to recover the heat (in winter) or cooling (in summer) and to transfer them and the moisture content from the exhaust stream into the incoming



fresh air stream. If moisture transfer is not required, a Heat Pipe could be used in place of the Heat Wheel.

### **C) Water Heating**

In one industrial application, there was a requirement for some 5MW of heating to provide hot water for reticulation around the site. A potential source for this heat was the exhaust from an existing steam turbine. A lamella Heat Exchanger was suspended in the turbine exhaust duct to recover the heat from the exhaust for water heating. To maintain continuity of supply when the turbine was not in use, provision was made for low pressure steam to be injected into the duct.

### **D) Paint Oven Exhaust and Heating**

It is required for operators of paint stoving systems and tinplate ovens to install fume incinerators in the oven exhausts to raise the temperature of the exhaust stream to at least 760°C for destruction of the odours. The operating costs of such incinerators become a very substantial part of the total oven running costs, and any heat recovery which can be achieved shows a very favourable return on investment.

By installing a high temperature heat exchanger, the exhaust stream between the oven and the incinerator can be preheated by the hot gases discharged from the incinerator. Heat recovery of 50% of the incinerator requirement would be typical. A further gain can come from the provision of a second heat exchanger downstream of this to transfer more of the heat from the discharge gases to the cold fresh air make-up into the oven (which compensates for the exhaust gases taken from the oven).

An alternative to the second heat exchanger is to inject some of the incinerator exhaust gases back into the oven in place of the separate oven heating system. As this becomes a direct heat exchange arrangement, there will be mass exchange as well as heat exchange, and pressure balancing will have to be carefully considered - not a job for the inexperienced! Due to the injection of the flue gases, the oven atmosphere will change from oxygen rich to

carbon dioxide rich and oxygen deficient. Depending on the process, this may be an advantage or a disadvantage, and precautions will also be needed to ensure the safety of personnel who may need to enter the oven for maintenance, either during operation, or shortly thereafter.

### **E) Spinning and Carding Room Air Conditioning**

In the wool processing industry, wool carding and spinning processes are carried out in rooms with close temperature and humidity control, to maintain constant the properties of the wool fibres and their performance during processing. The ideal air conditions call for warm temperatures and high humidity. The heat load from the machinery is significant and cooling is required over much of the year.

One such plant utilises deep bore artesian water for the scouring and dyeing operations, but first passes the water through air washers in the Spinning and Carding Room air conditioning systems. The water cools the room return air, and increases its humidity. In turn, the water is heated prior to its use in the scouring and spinning departments. The same water gives operating cost savings to both departments.

### **F) Dye House Water Heating**

In the same plant, this water is further heated through a Plate Heat Exchanger by the waste liquor from the dye vats. The waste has a high wool fibre loading, and tends to foul normal exchanger surfaces easily. The design of the plate exchangers is such that high flow velocities and turbulence keep the surfaces free from such fouling for acceptable times, but the system provides for three exchangers, two on-line and one off-line to provide for cleaning. In addition, the exchangers are fitted with pneumatic cylinder closures in place of the normal clamping bolts, to allow for rapid opening for cleaning.

In each of these examples, the selection of appropriate matching between the exchangers and the duties has been achieved by consideration of the benefits and constraints listed above. Each application is different, and careful evaluation is needed to obtain optimum solutions.

There are some applications where economics determine that the cost of achieving energy savings do not warrant the expenditure, but these are not as common as may at

first appear, and an alternative approach may still bring an appropriate solution.

## Pinch Technology

Pinch Technology represents a powerful way to analyse heat and power interactions in an industrial process. This process integration technique allows the plant or site to be integrated as a whole - a feature not available with traditional design methods.

With this approach, managers and engineers can:

- target minimum energy consumption
- identify process modifications that reduce energy use
- design/redesign processes to meet these energy targets
- minimise capital cost

The result of studies in various industries has been energy savings of between 20% and 40%. For design of new facilities, energy savings are often accompanied by significant reductions in capital costs.

Pinch Technology is non-process specific and can be applied to all process industries in New Zealand such as meat, dairy, and pulp and paper.

When one process stream needs to be heated and another cooled, engineers have typically concentrated mainly on individual production units rather than looking at the overall processing through the plant.

A Pinch Study looks at understanding all of the heat recovery opportunities within a plant. Looking at the whole picture rather than looking for those easily identified projects where the investment meets short payback period criteria, allows greater energy savings to be identified.

### Pinch Technology Analysis

In a typical industrial process various streams of material are heated and cooled over a wide temperature range. The amount of heat transferred between the hot and cold streams and the temperatures where it occurs can be graphically shown as composite curves.

The overlap region between the composite curves indicates the potential heat recovery. The driving force for this heat recovery is represented by the vertical separation between the curves. By introducing a minimum temperature difference (DT min - an estimate of the economic break-even point between the cost of heat exchangers and the cost of energy recovered) the minimum external heating and cooling requirements can be determined. This DT min can be further optimised.

The temperature at the point of closest approach between the hot and cold composite curves is called the process 'pinch'. Only the minimum amount of external heating and cooling will be required provided the three golden rules of Pinch Technology are followed:

- Don't use external cooling above the Pinch
- Don't use external heating below the Pinch
- Don't transfer heat across the Pinch

Once this minimum energy use is determined, the heat exchanger network, and the heat and power systems can be modified to meet these targets. This graphical technique simplifies analysis of identifying energy savings and allows optimum design of heat recovery systems.



Emprove is a service provided by the Energy Efficiency and Conservation Authority (EECA). EECA is a Crown entity working to improve New Zealanders' energy choices.

**Auckland:** PO Box 37-444, Parnell, Auckland  
Telephone 09 377 5328, Fax 09 916 4643

**Wellington:** PO Box 388, Wellington  
Telephone 04 470 2200, Fax 04 499 5330

**Christchurch:** PO Box 8562, Riccarton, Christchurch  
Telephone 03 341 1126, Fax 03 341 8571

[www.emprove.org.nz](http://www.emprove.org.nz)

